

This manual is for reference and historical purposes, all rights reserved.

This page is copyright© by M. Butkus, NJ.

This page may not be sold or distributed without the expressed permission of the producer

I have no connection with any camera company

On-line camera manual library

This is the full text and images from the manual. This may take 3 full minutes for the PDF file to download.

If you find this manual useful, how about a donation of \$3 to: M. Butkus, 29 Lake Ave., High Bridge, NJ 08829-1701 and send your e-mail address so I can thank you. Most other places would charge you \$7.50 for a electronic copy or \$18.00 for a hard to read Xerox copy.

This will allow me to continue to buy new manuals and pay their shipping costs.

It'll make you feel better, won't it?

**If you use Pay Pal or wish to use your credit card,
click on the secure site on my main page.**

Canon

AE パワーワインダー FN

使用説明書 ニュー・キヤノンF-1用

AE POWER WINDER FN

Instructions For the New Canon F-1

MOTEUR D'ARMEMENT EA FN

Notice d'emploi Pour le nouveau Canon F-1

POWER WINDER AE FN

Bedienungsanleitung Für die neue Canon F-1

BOBINADOR

MOTORIZADO FN PARA AE

Instrucciones Para la nueva Canon F-1



目次

主要性能	P. 5
カメラに取り付ける前に	P. 7
カメラへの取り付け	P. 8
撮影前に	P. 8
撮影	P. 9
多重露出	P.10
シャッター優先 AE 撮影について	P.11
カメラのメカニカルシャッターを利用する場合	P.12
フィルムの巻き戻し	P.12
リモート撮影およびインターバル撮影	P.13

CONTENTS

Specifications	p.15
Loading the Batteries	p.16
Attaching the Power Winder to the Camera	p.17
Setting the Frame Counter	p.18
Shooting	p.18
Shutter Release	p.20
Rewinding the Film	p.21
Multiple Exposures	p.22
Remote Control	p.22

TABLE DES MATIERES

Fiche technique	P.25
Mise en place des piles	P.26
Montage du moteur d'armement sur l'appareil	P.27
Réglage du compteur d'images	P.28
Prise de vue	P.29

Déclencheur	P.31
Rebobinage du film	P.32
Expositions multiples	P.33
Télécommande	P.33

INHALT

Technische Daten	S.35
Einlegen der Batterien	S.36
Einige Batterie-Tips	S.37
Ansetzen des Power Winder AE FN an die Kamera	S.37
Zählwerk	S.38
Aufnahmen mit dem Power Winder AE FN	S.38
Auslöser und Auslöser-Feststeller	S.40
Filmende und Rückspulen	S.41
Mehrfachbelichtungen	S.42
Fernsteuerung	S.42

INDICE

Especificaciones	P.45
Carga de las pilas	P.46
Instalación del bobinador motorizado a la cámara	P.47
Ajuste del contador de fotos	P.48
Disparo	P.49
Disparador	P.51
Rebobinado de la película	P.52
Exposiciones múltiples	P.53
Control remoto	P.53

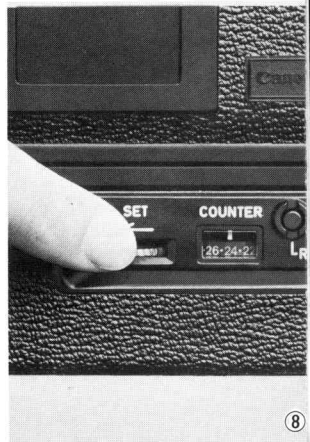
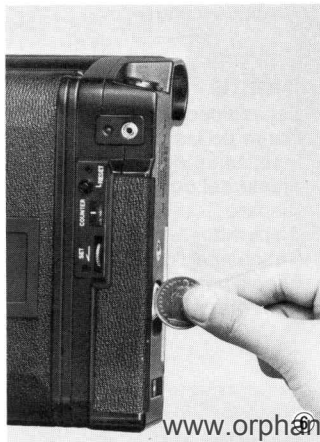
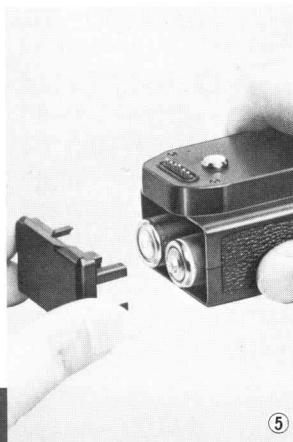
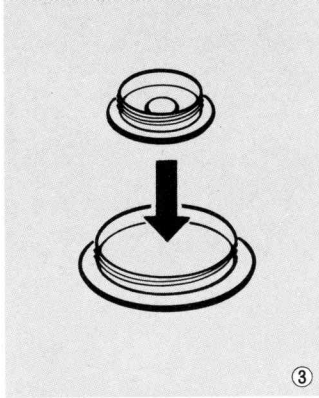
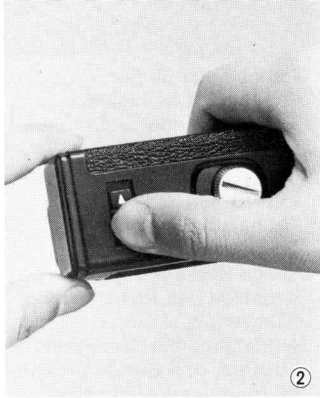

キヤノン AE パワーワインダー FN

キヤノンAEパワーワインダーFNは
ニュー・キヤノンF-1専用のフィル
ム自動巻き上げ装置ですが、ニュー
F-1にシャッター優先AE機能を追加
する機構も備えています。

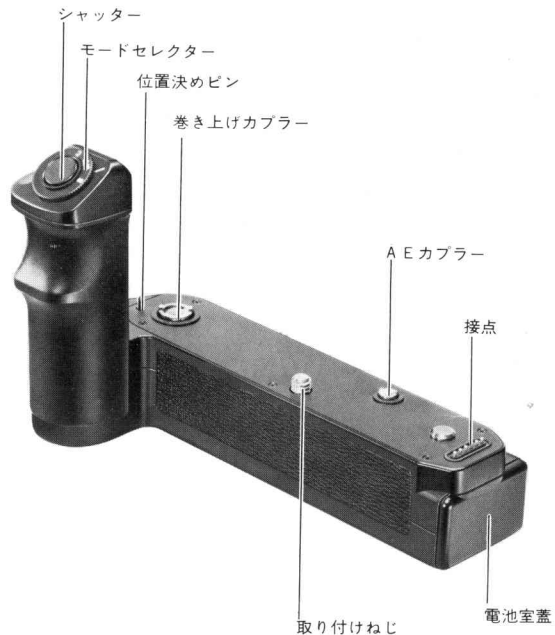

主要性能

型式：シャッター優先 AE 機能を付加する機構を備えた電動巻き上げ装置。

使用カメラ：ニュー・キヤノンF-1

電源：単3型電池4本 (Ni-Cd電池使用可)

装着法：三脚ねじ穴利用。

シャッターレリーズ：カメラ側およびワインダー側のシャッターボタン使用，レリーズロック付。

シャッターレリーズ停止安全機構：

- ①警告ランプ点燈中。
- ②カメラ本体の電池電圧低下時。
- ③シャッター優先 AE モードで使用時，ワインダー内電池の電圧が低下した時。

駆動モード：モードセクターによる。

“C”は連続撮影(秒間約2コマ)，“S”は1コマ撮影。(シャッターボタンを押すと撮影，離すと巻き上げ)

使用可能シャッタースピード範囲：8秒～1/2000秒

*カメラ本体の電池を外した場合は1/90秒～1/2000秒(カメラの機構による)

*Bの時はバルブ。(カメラ側シャッター利用)

フィルムカウンター：逆算式，フィルム巻き上げに



Canon AE Power Winder FN

Designed to increase the versatility of the New Canon F-1, the AE Power Winder FN advances the film automatically in single-frame or continuous shooting at a maximum two frames per second. In addition, it converts the camera to shutter-priority AE, the ideal exposure mode for sports, candid and action photography. The power winder has two shutter release buttons for convenient shooting in either the horizontal or the vertical format, and a remote control socket.

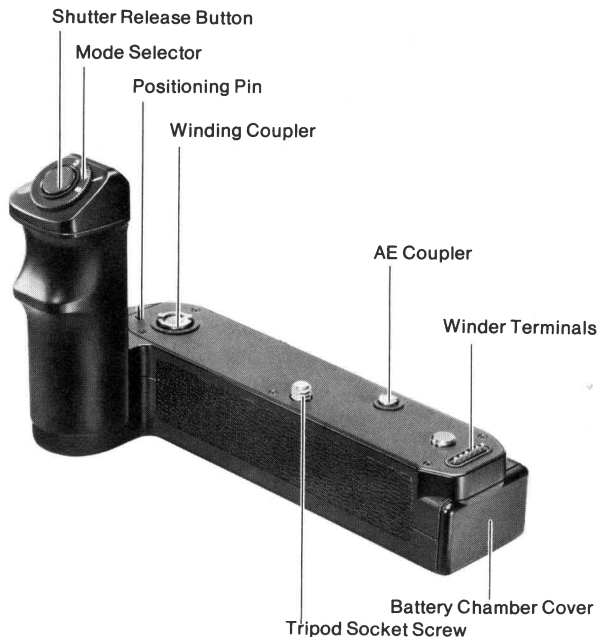

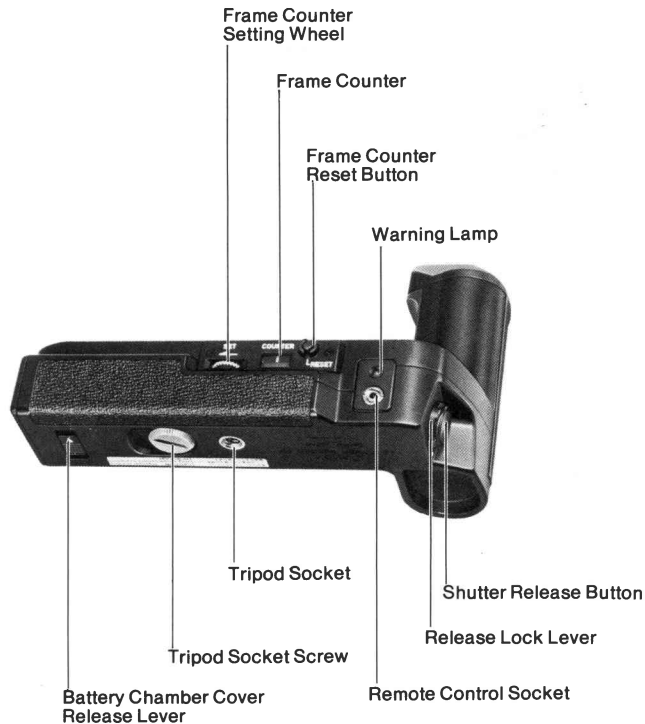

Specifications

Compatible with: New Canon F-1

Type: Electromotive film winding device with a provision for converting the camera to shutter-priority AE.

Shutter-Priority AE: By attaching the power winder to the camera and setting the aperture ring of an FD or New FD lens to the "A" mark.

Attachment: By using tripod socket on the camera after removing the winding coupler cover and AE coupler cover on the bottom of the camera.

Shutter Release: Three shutter buttons (horizontal and vertical format plus camera's) are available. With release button locks. Safety circuit prevents shutter release when camera's or power winder's battery power is insufficient and when warning lamp lights up.

Film Driving Speeds: Set with mode selector. "C" for continuous shooting at a maximum 2 fps. (Shutter continuously released and film automatically wound as long as the shutter button is pressed.) "S" for single-frame shooting. (Shutter released when the shutter button is pressed and film automatically wound when finger is removed from shutter button.)

Manual Film Advance: By turning off mode selector and using the camera's advance lever.

Shutter Speed Range: 8 secs. to 1/2000 sec.

Power Source: Four size-AA 1.5V carbon-zinc or alkaline batteries. Ni-Cd batteries may also be used.

Battery Life: Approximately 20 rolls of 36-exposure film with new carbon-zinc batteries at normal temperatures.

Frame Counter: Reverse-counting type. Functions inde-

pendent of camera's frame counter. Automatically stops at "0" and warning lamp lights up.

Frame Counter Setting: By setting wheel. Counter automatically resets to "S" when reset button is pressed.

Film Rewinding: Using rewind crank on camera.

Warning Lamp: Lights up when frame counter reaches "0" or when power winder's battery voltage drops below operating level.

Remote Control: By using Remote Switch 3 or 60, Wireless Controller LC-1, or other external control devices connected to 2.5mm-diameter remote control socket on the power winder.

Interval Photography: By using Time Lapse Programmer A and B units or Interval Timer TM-1 Quartz.

Dimensions and Weight: 157.2(W) × 101.3(H) × 76.5(D) mm (6-3/16" × 4" × 3"); 400g (14-1/8 ozs.) including batteries.

Subject to change without notice.

Loading the Batteries

The battery in the camera cannot be removed once the power winder is attached. Therefore, always check the condition of the camera's battery before mounting the power winder. Refer to the instruction manual of the New Canon F-1 for procedures on checking the battery.

Use four new size-AA carbon-zinc, alkaline, or fully-charged Ni-Cd batteries. Before loading the batteries, their contacts should be wiped with a clean, dry cloth to prevent corrosion due to dirt or fingerprints.

1. Using a coin, unscrew the winding coupler cover and AE coupler cover from the bottom of the camera ①.

CAUTION:

Do not remove the rewind coupler cover or, if film is loaded in the camera, this may expose the film to light.

2. Then slide the battery release lever in the direction of the arrow ② and remove the battery chamber cover. Stack the two coupler covers, placing the AE coupler cover on top of the winding coupler cover ③, and insert them in the cover storage section provided in the battery chamber to prevent losing them ④. Be careful not to drop the coupler covers inside the battery chamber.
3. Insert the batteries as indicated by the diagram inside the battery chamber.
4. With the notched portion of the battery chamber cover facing up, align the cover with the batteries ⑤ and push it in until it locks in place. It can be inserted in only one direction.

Notes

1. Be sure to load the batteries correctly. If incorrectly loaded, the batteries may leak, damaging the winder.
2. When changing batteries, replace all at the same time with four new ones of the same brand.
3. Remove the batteries if the power winder will not be used for about three weeks or longer.
4. Size-AA Ni-Cd batteries are recommended for use in cold weather. When purchasing Ni-Cd batteries, make certain they are compatible with the power winder.
5. About 20 rolls of 36-exposure film can be wound continuously at normal temperatures using new carbon-zinc batteries.

Attaching the Power Winder to the Camera

Using a clean, dry cloth, wipe the winder terminals on the bottom of the camera and the contact pins on the power winder to ensure proper contact.

1. Make sure the mode selector on the power winder is OFF.
2. Then align the power winder's attachment screw and positioning pin with the tripod socket and positioning hole on the bottom of the camera. Using a coin, tighten the attachment screw to secure the power winder to the camera ⑥.

When mounting the power winder, make sure the camera's neckstrap ring does not lie between the camera body and the power winder's grip.

Note:

Make it a rule to turn OFF the mode selector when mounting or dismantling the power winder and when it is not in use.

Setting the Frame Counter

1. Press the frame counter reset button before loading the film. This will return the frame counter to "S" ⑦.
2. Open the camera back and load the film. Insert the film leader into one of the slots of the take-up spool and, using the camera's film advance lever, advance one frame of film. Make sure the film perforations are engaged with the sprocket teeth.
3. Close the camera back and take two blank shots. Then turn the advance lever once more; the frame counter will read "36."
4. When loading a roll of film with fewer exposures than 36, such as 24 or 12, first follow the steps above. Then push in and turn the frame counter setting wheel in the direction of the arrow until "24" or "12," for example, is aligned with the counter index ⑧.

Notes

1. The frame counter setting wheel will turn only in the direction of the arrow. If you turn past the number you intend to set, press the reset button and start over from "S."
2. Do not set the frame counter to a number larger than the number of frames on the film. If the counter is set to a larger number and the film ends before the frame counter reaches "0," the film perforations may be torn.
3. The frame counter of the power winder is a reverse-counting type while that of the camera is an additive type. Consequently, their readings will not be the same.

Shooting

Set the desired film driving speed by pulling up and turning the mode selector until "S" or "C" is aligned with the index ⑨.

At the "S" position, a single exposure is made when you press any of the three shutter release buttons, and the film is automatically advanced when you remove your finger from the button. At the "C" position, continuous photography at about two frames per second is performed as long as you press any of the shutter release buttons.

I. Shutter-priority AE Photography

One of the primary functions of the AE Power Winder FN is to convert the New F-1 to shutter-priority automatic exposure (AE). This AE mode is possible only when using an FD lens. Note that center-weighted average metering is recommended in general for AE photography.

1. Turn the aperture ring of the lens, while pressing the AE lock pin, until the "A" mark is aligned with the distance index ⑩.
2. Set the New F-1's shutter dial to the desired shutter speed. Shutter speeds from 8 secs. to 1/2000 sec. can be used; the "B," " $\frac{1}{2}$ " and "A" settings on the dial cannot be used in the shutter-priority AE mode.
3. Look into the viewfinder and lightly press one of the shutter buttons to get a meter reading. The meter needle will point to the f/stop the New F-1 has selected automatically. For correct exposure, the meter needle should not be in either the over- or underexposure warning zone. If it is in either zone, turn the shutter dial until the meter needle moves out of the warning zone.

4. Press the shutter button all the way down to take the picture.

Notes

1. If there are no batteries in the power winder, or if they are loaded and their voltage drops below operating level, shutter-priority AE photography is impossible. In this case, setting the lens' aperture ring to the "A" mark will lock all shutter buttons, thus preventing shutter release. To use the camera in the manual exposure mode, simply remove the lens' aperture ring from the "A" mark and set an aperture in the usual manner.
2. Shutter-priority AE photography is possible even if the mode selector is OFF, as long as the lens' aperture ring is on the "A" mark. In this case, the film will not be advanced automatically and the shutter must be released with the camera's shutter button or the winder's vertical-position shutter button.
3. For self-timer photography or for releasing the shutter with a remote control device, close the built-in eyepiece shutter of the camera to prevent light from entering the eyepiece and adversely affecting automatic exposure.

II. Manual Override

The New Canon F-1 functions as a manual-exposure camera when the lens' aperture ring is moved from the "A" mark. Then simply determine correct exposure in the usual manner by setting both shutter speed and aperture, matching the meter and aperture needles in the viewfinder. For further details, refer to the instruction book of the camera.

Note:

Press the shutter button on the camera when shooting with the shutter dial on "B." If either of the power winder's shutter buttons is pressed, the shutter speed will switch automatically to 1/1000 sec.

III. Mechanical Operation

When the battery is removed from the camera, the New F-1 switches to mechanical shutter control. In this case, only single-frame photography is possible even if the mode selector on the power winder is set to "C." Only the shutter release button on the camera can be used to release the shutter. The mechanically controlled shutter speeds are 1/2000 to 1/125 sec., " $\frac{1}{2}$ " (1/90 sec.) and "B." If the camera's shutter dial is set to a shutter speed slower than 1/90 sec., the speed will switch automatically to 1/90 sec. For further details, please refer to the instruction book of the camera.

Shutter Release

Two shutter release buttons are provided on the power winder for maximum ease of handling **(1)**. For horizontal shots, use the shutter button on top of the grip. Use the shutter button on the side of the power winder for vertical shots. Of course, the camera's shutter button can also be used.

The shutter release buttons are provided with release button locks. The shutter button on top of the grip can be locked by pulling up and turning the mode selector to OFF. The shutter button of the camera or the vertical-position shutter button of the power winder will still release the shutter when pressed. However, in this case automatic film advance will not occur. To lock the vertical shutter button, turn the lock lever so that the red "L" is aligned with the white dot. This is recommended to prevent accidental shutter release when carrying the camera.

The three shutter release locking devices function independently of each another. Even if the camera's shutter release lock lever is aligned with the "L," for example, either of the power winder's shutter release buttons can still be used to release the shutter.

Note:

Do not depress the film rewind lever on the camera during power winder operation unless you wish to take multiple exposures (see p. 22).

The shutter will not operate in the following cases:

1. When the camera is used in the shutter-priority AE mode and the power winder has no batteries installed or, if installed, their voltage is insufficient. In this case, replace the batteries.
2. When the camera's battery does not have enough voltage to power the camera. In this case, replace the battery in the camera.
3. When the power winder's warning lamp lights up. In this case, rewind the film immediately.

Rewinding the Film

Film winding stops automatically and the warning lamp lights up when the frame counter reaches "0." Rewind the film immediately or turn OFF the mode selector on the power winder after the lamp lights up. Otherwise, the warning lamp will remain on and eventually drain the batteries.

1. First press the frame counter reset button ⑫ .
2. Then turn the rewind lever on the camera clockwise and press it down ⑬ .
3. Unfold the rewind crank and turn it in the direction of the arrow. As you turn the rewind crank, you will hear a sound which indicates the film is being rewound. When you no longer hear the sound, the film is rewound completely. If the mode selector has not been turned OFF, the warning lamp will stay on. After rewinding the film, turn the film advance lever until it stops; the light will go out ⑭ . Then open the camera back and remove the film from the camera.

Notes

1. If the film is rewound without first pressing the frame counter reset button, the warning lamp will stay on and the power winder will not operate when you press the shutter button because the counter is still at "0." In this case, press the counter reset button and turn the film advance lever.
2. The film will not advance if the camera's rewind lever is engaged. Before loading the next film, be sure to lightly press the camera's shutter button to disengage the rewind lever.
3. After removing the power winder from the camera, do

not forget to remove the lens' aperture ring from the "A" mark. Otherwise, the camera's automatic safety circuit will prevent shutter release if there is a battery in the camera.

E

Multiple Exposures

Multiple exposures are possible when the AE Power Winder FN is attached to the camera. The film must be taut before making the first exposure. To take up any slack in the film, unfold the camera's rewind crank and gently turn it in the direction of the arrow until it stops. Then turn and press the camera's rewind lever in the usual manner; the film will now remain stationary for multiple exposures. The mode selector can be set to either the "S" or "C" position. To release the shutter, press either shutter button of the power winder. The frame counters of both the camera and the power winder will advance each time the shutter is released.

You can make any number of exposures on the same frame simply by pressing one of the power winder's shutter buttons. However, there is possibility of a slight movement of the film if you make an excessive number of exposures on the same frame. Also note that, depending on the number of exposures made on the frame, exposure compensation is necessary to prevent overexposure. Refer to the camera's instruction book for further details.

To return to normal shooting, cap the lens and take a blank shot, using the camera's shutter button.

Notes

1. To check the tension of the film, the rewind crank must be unfolded before it is turned; otherwise, it will turn freely.
2. It is not advisable to make multiple exposures on the first or last few frames of the film.

Remote Control

A 2.5 mm socket is provided on the AE Power Winder FN for connecting accessories for remote control and interval-timer photography.

Remote Switch 3 or 60, the Wireless Controller LC-1, the Interval Timer TM-1, or other remote control devices may be plugged into this socket.

With the mode selector on OFF, connect the accessory to the remote control socket (15). If the mode selector is not OFF, the shutter may be released, thus wasting one frame. After connecting the accessory, turn on the power winder's mode selector or remote control will be impossible.

Note:

There is no viewfinder display when a remote control device or interval timer is used with the power winder.